

RIFLE

SPORT FAIRING MOUNTING INSTRUCTIONS

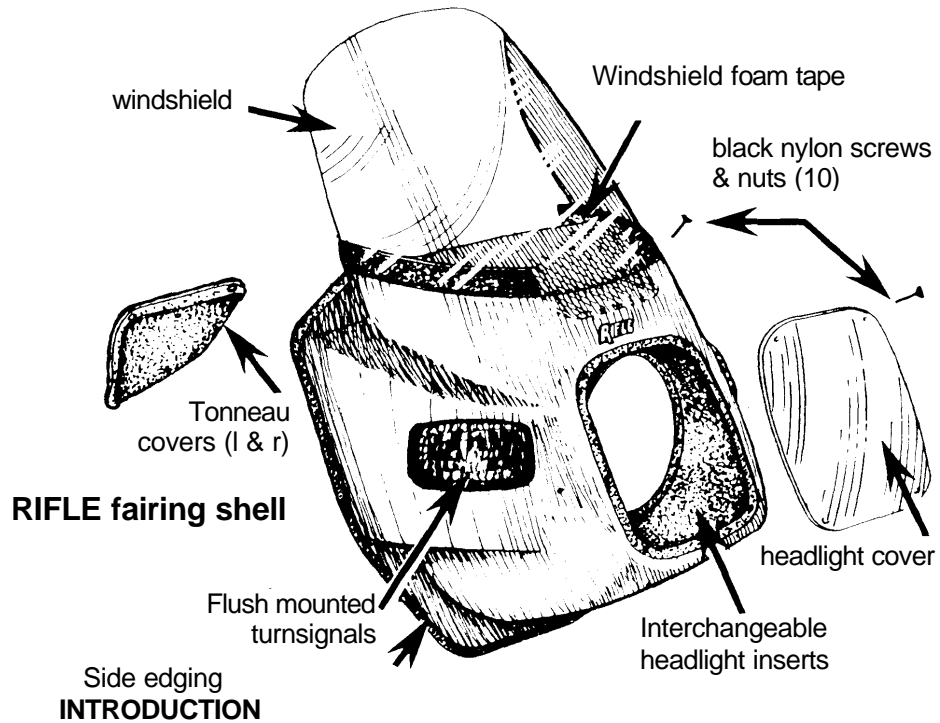

INTRODUCTION

These instructions contain important information regarding the proper installation and maintenance of your new **RIFLE** fairing. Read it completely and follow the recommendations for the most trouble free and enjoyable use. Statements preceded by the following words are of special significance.

WARNING:

means there is a possibility of injury to yourself and others if instructions are not followed.

CAUTION:

means there is a possibility of damage to the product if instructions are not followed.

NOTE:

indicates points of special interest.

The **RIFLE** system of interchangeable headlight inserts and exclusive forkleg/top triple clamp mounting enables the **RIFLE** fairing to fit almost any motorcycle.

Because of this, these mounting instructions are intended to serve as a general installation guide rather than step by step instructions for individual motorcycles. **YOUR** motorcycle's installation may vary from normal and require some interpretation and ingenuity. If you experience a serious problem in installation contact us, we may already have the solution. In any case, do not cut up or modify the fairing without checking with us first or your warranty will be voided.

NOTES:

- 1) Make sure you have the correct headlight insert for your bike (6" round; 7" round; 8" round, rectangular; and Harley-Davidson).
- 2) Check the special mounting parts list on page 7 to see if your bike needs any special parts
- 3) For convenience we recommend that your headlight be properly adjusted before you install your **RIFLE** fairing

PREPARE YOUR MOTORCYCLE

- 1. Remove your bike's stock front turnsignals. Note the turnsignal, running light and ground wire colors for each side as you will have to connect them to the corresponding **RIFLE** turnsignal wire assemblies using the supplied Scotchlock connectors as shown.

RIFLE Turnsignal Leads (2 per fairing)

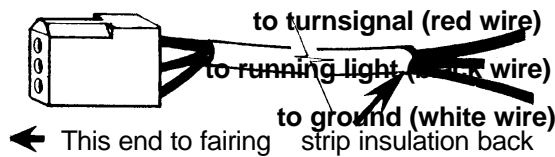

NOTE:

The connectors will splice the individual motorcycle wires. If you have a BMW and want a neat custom installation, get some 1/4" quick disconnect terminals at your local store, crimp them to the **RIFLE** wires and plug them into the BMW terminal board.

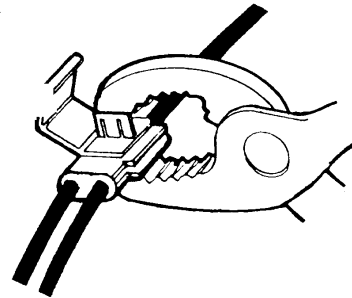

NOTE:

On most bikes these connections take place inside the headlight shell and the **RIFLE** wire assemblies should then exit the shell through existing holes and be allowed to hang free until after the fairing is mounted.

2. Remove your bike's top triple clamp pinch bolts and install either the 90° or 120° top brackets as shown. The object is to have these brackets pointing straight forward. You can bend them slightly if necessary.

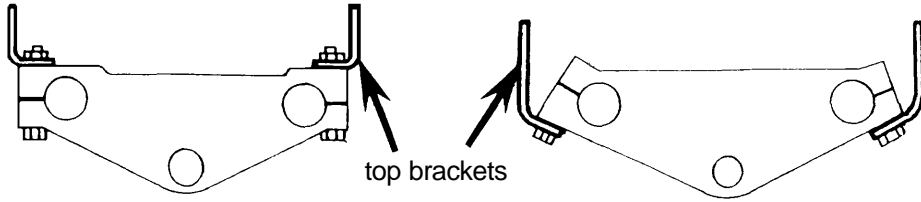

NOTES:

- 1) These brackets not needed on some Hondas. See special Honda **NOTE** on next page.
- 2) These brackets can attach either to the front side or the back side of the triple clamp - whatever is more convenient.
- 3) We have special brackets available for those few bikes (like BMW) that have no pinch bolts. Contact us for information.

WARNING:

Proper triple clamp pinch bolt tightening torque is essential to insure your bike's safe handling. If you do not have the proper torque specs, tools or experience, see your dealer.

3. Using 8mm bolts, washers and locknuts, bolt the slotted uprights to the **RIFLE** triple clamp brackets.

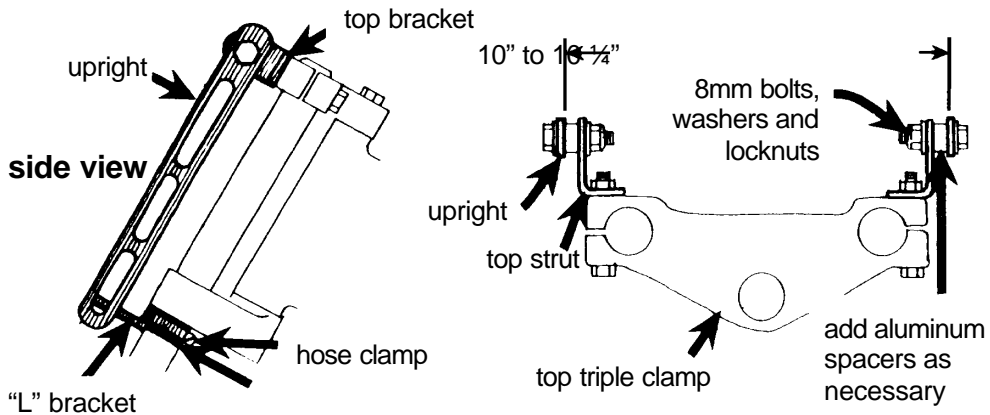

These uprights should be parallel to the fork tubes, and should measure about 10" to 10 1/4" apart from each other. As different triple clamps vary, 1/4" and 1/2" thick aluminum spacers are provided for adjustment. If no spacers are necessary, use the 8x25mm bolts. If spacers are required, use the longer 8x35mm bolts. Also, use washers under bolt heads and nuts.

HONDA NOTE:

Many Hondas (V65, V45, Sabre, 650 Nighthawk, 750 Shadow, VT500 Ascot, etc.) have the stock turnsignal hole located on the headlight stay. In these cases, using the 1/2" spacers you can bolt the upper end of the upright (usually through the second slot from the top) directly to the vacant turnsignal hole, thus eliminating the 90° or 120° top bracket

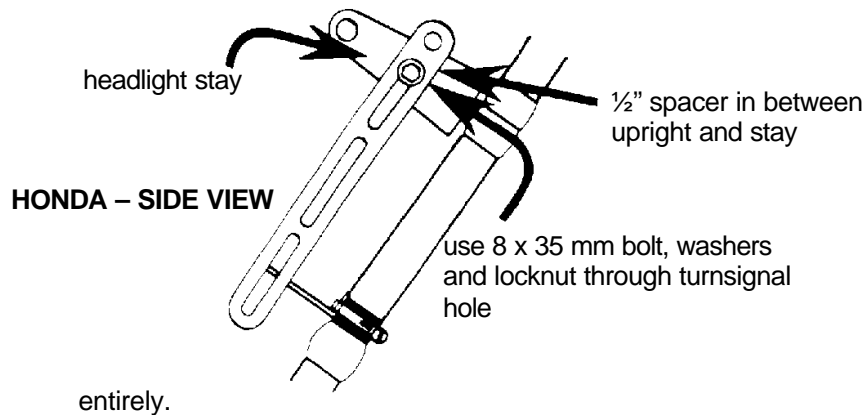

4. Cut the 9" length of rubber tape in half, remove the protective backing and wrap the tape around the fork legs right under the lower triple clamp. Attach the "L" brackets to the rubber covered fork leg with the hose clamps as shown.

5. Connect the uprights to the "L" brackets with the remaining "L" brackets and 6mm bolts, washers and locknuts as shown.

bottom view

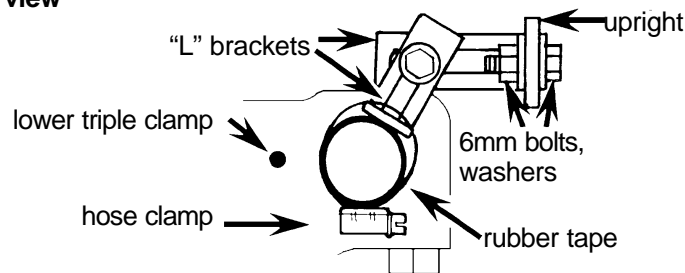

MOUNT THE FAIRING

1. The fairing top struts connect the fairing to the uprights and are adjustable for length and angle by virtue of multiple holes in the strut and two sets of mounting holes in the fairing interior. Hold the fairing up to the bike's headlight making sure it's centered and straight. Eyeball the correct holes to use for attaching the struts to the fairing. Bolt the top struts to the fairing interior using 6mm bolts and locknuts with rubber side of the Aztec washers against the plastic.

2. Bolt the fairing mounted upper struts to the bike mounted uprights using 8mm bolts, washers and locknuts.

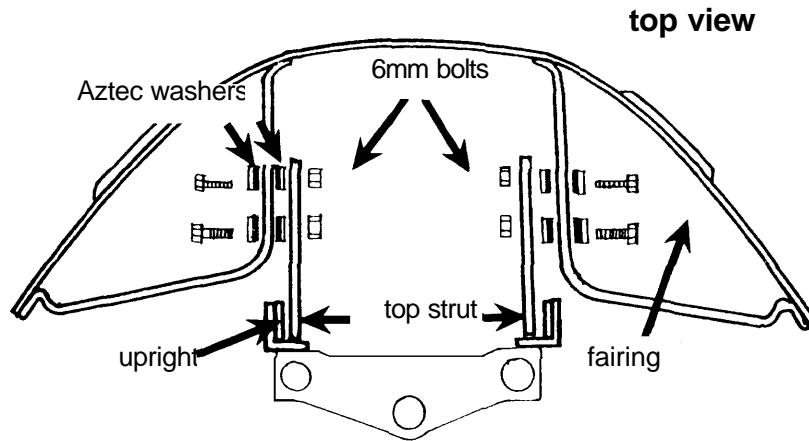

NOTE:

The fairing struts can be mounted between the uprights or the outside of them. The important thing is to avoid putting a lot of stress on the plastic as you tighten the bolts. Change the spacing of the uprights to the top brackets if necessary to avoid bending stress on the plastic.

3. Attach one end of the lower struts to the holes in the fairing interior using 6mm bolts, Aztec washers and locknuts. Bolt the other end of the lower strut to the lower slot in the upright as shown.

NOTE:

Two different length lower struts are provided to accommodate your bike.

4. Thread the turnsignal leads through the holes in the pockets and connect them to the turnsignal wiring in the pocket.

side view

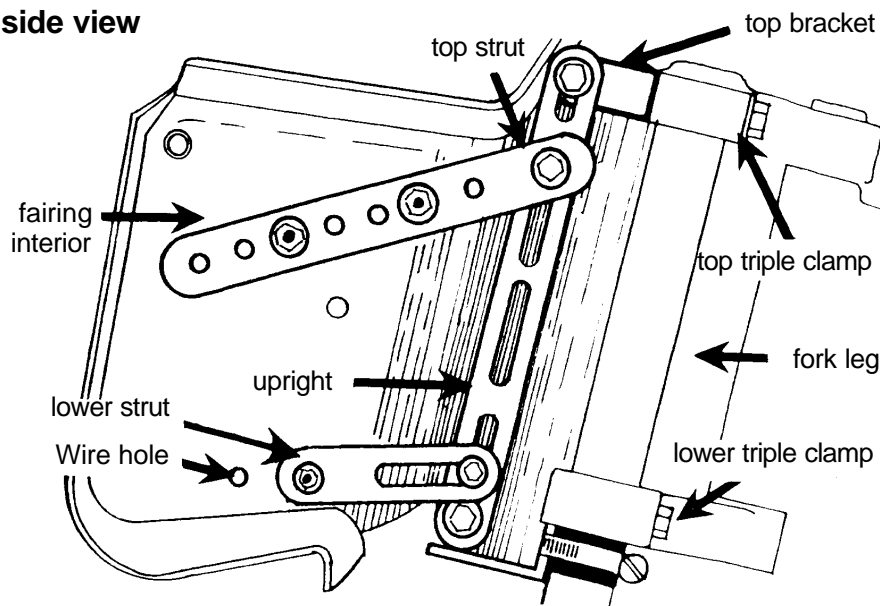

5. Mount the windshield to your fairing using the supplied nylon screws and nuts.

CAUTION:

Snug up, but do not over-tighten the nylon screws.

OPERATION AND MAINTENANCE TIPS

HORNS - If the fairing blocks your bike's horns, it is usually possible to bend the horn mounts down 45° so the horns clear and the sound is not trapped behind the fairing. In exceptional cases you may want to relocate the horns. Horns need to vibrate a little to work so try to use the stock horn mounts.

FASTENERS - Check all fasteners periodically for tightness paying special attention to hose clamps and nylon fasteners.

WARNING:

Keep your headlight cover clean. Any headlight cover will reduce the light transmitted from your headlight even when clean, so it is vital to keep the cover clean. We also recommend you use a halogen headlight conversion if your bike does not already have one.

WINDSHIELD AND HEADLIGHT COVER CLEANING - Use mild soap and water or glass cleaners like Windex and a soft cloth. Do not use solvents or abrasive cleaners. Scratches can usually be removed with plastic polish or automotive cleaner waxes.

NOTE:

New headlight covers are available. Headlight covers may become illegal in some states. Check your local laws. If there is a problem, remove the lens. The only drawback will be a slight increase in air drag.

CAUTION:

Never allow brake fluid to come in contact with the fairing or windshield.

URNSIGNAL - If a bulb burns out, replace it with a standard automotive bulb available at any gas station or auto parts store.

REPAIRS - Our testing indicates that structural damage to the fairing may be repaired with fiberglass cloth and resin kits available at auto parts stores. Sand the plastic surface to be repaired first, and follow the kit instructions. Other products that work are the various glass-filled body putty products with brand names like "Tigers Hair" and "Dyna-Glas" etc., used to repair Corvette bodies.

PAINTING TIPS - Your RIFLE fairing can be repainted using standard automotive acrylic enamel or polyurethane paints (avoid Lacquer it may adversely affect the plastic.)

SPECIAL SPORT MOUNTING PARTS

BMW/5 Kit (special top and bottom brackets)









BMW/6/7 Kits & R100 (special top & bottom brackets plus key relocation kits)

Yamaha Bolts for models 750 Maxim, 750 Seca and 1100 Maxim ONLY (special 8mm bolts)

Suzuki Brackets for most all Suzuki models (top 120° brackets drilled out to accommodate larger than standard pinch bolts)

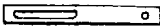
Suzuki Uprights (special longer uprights for GSX1100G)

STANDARD "SPORT" HARDWARE KIT

Top Brackets, 90°		2
Top Brackets, 120°		2
Uprights		2
Top Struts		2
Lower Struts, Long		2
Lower Struts, Short		2
"L" Brackets		4
#20 Ho		2
Aztec 1		12
Rubber Tape 9" Long		1
Spacers, 1/4 inch		2
Spacers, 1/2 inch		2
8x35mm Bolts		2
8x25mm Bolts		4
8mm Washers		8
8mm Locknuts		4
6x20mm Bolts		12
6mm Washers		12
6mm Locknuts		12
Turnsignal Leads		2
Scotchlock Connectors		6

“SPORT” OPTIONS AND REPLACEMENT PARTS

Standard Sport Hardware Kit

Headlight Insert (specify 5", 6", 7", 8", rectangular)

15" clear windshield

15" tint windshield*

18" clear windshield

18" tint windshield*

21" clear windshield

21" tint windshield*

***WARNING:** Tinted windshields are not for nighttime use unless you look over the windshield in the normal riding position.

Handflares

Dash / Instrument panel

Headlight cover

Windshield foam gasket

Bag of 12 nylon screws and nuts

Turnsignal complete

Turnsignal lens only

Turnsignal lead wire

Tonneau cover for storage pocket (specify left or right)

Side edging

RIFLE PRODUCTS - This warranty applies to products manufactured or distributed by **RIFLE**, 3140 El Camino Real, Atascadero, CA 93422, (805)466-5880, and sold by **RIFLE** and its authorized dealers. It is given to the first retail purchaser only and is not transferable to subsequent owners.

WARRANTY OBLIGATION RIFLE - warrants that it, or one of its authorized dealers, will repair or, at its option, replace any part proven to be defective in factory material or workmanship within one year (unlimited mileage) of the date of purchase. Parts repaired or replaced under this warranty are warranted only during the balance of the original warranty period. This warranty does not include any labor charges for troubleshooting, removal, installation or shipping costs.

EXCLUSIONS FROM COVERAGE - Any repairs or replacements of parts necessitated by misuse, negligence, fire, accident, damage caused by exposure to gasoline, brake fluid, harmful solvents and cleaners, paints, or repair material, use of unauthorized accessories or faulty installation, improper or unreasonable maintenance are not covered.

DISCLAIMER OF CONSEQUENTIAL DAMAGES AND LIMITATIONS OF IMPLIED WARRANTIES - To the extent the law permits, RIFLE shall not be liable under any circumstances for loss of use of the product, consequential or incidental damages. Any implied warranty arising under law, including those of merchantability and fitness for a particular purpose is limited to duration of this limited warranty.

IMPORTANT - Some states do not allow limitations on how long an implied warranty lasts and/or limitations or exclusions of consequential or incidental damages, so the above limitations may not apply to you.

WARRANTY REGISTRATION/QUESTIONNAIRE

For your warranty to be valid, you must fill out and mail this page to
RIFLE, 3140 El Camino Real, Atascadero, CA 93422

Name _____

Address _____

City _____ State _____ Zip _____

RIFLE Model Purchased: Sport Superbike Nightflight Roadster

Date of Purchase: _____

Where did you purchase: _____

Dealer Name and Address: _____

Your Bike Make: _____ Model: _____

Size (cc): _____ Year: _____ Color: _____

Did you consider buying a fairing other than RIFLE? _____

If yes, which one? _____

Why were you attracted to RIFLE? _____

What motorcycle magazines do you buy most?

Cycle World Motorcyclist Rider M/C Consumer

Other _____

Did you install the fairing yourself? _____

What do you like **least** about the fairing? _____

What accessories will you buy next for your bike? _____

FOLD HERE

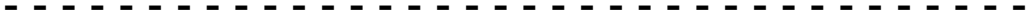

stamp
here

RIFLE

3140 El Camino Real
Atascadero, CA 93422

Copyright© by RIFLE