

RIFLE CAN AM SPYDER WINDSHIELD MOUNTING INSTRUCTIONS

A. Removing the Spyder Windshield

1. Remove the four mounting screws.
2. Store away the four screws and windshield.

B. Mounting the Rifle Windshield

1. Place two stainless steel screws through aluminum washers, through the windshield's two bottom holes, through the long aluminum spacers – rubber washer against the windshield surface -, and into the two bottom threaded mounting holes in the fairing. Rotate the spacers so that the mark on the lowest height is pointed toward the ignition key. See Fig. 1. Turn in the screws very loosely.
2. Place one of the short aluminum spacers between the windshield – rubber washer against the windshield surface – and the fairing at the upper right threaded windshield mounting hole. Rotate the spacer so that the mark on the lowest height is pointing toward the ignition key. Push a screw through the assembly and turn it in very loosely.
3. Repeat step 2 with the upper left mounting screw.
4. If the spacers are properly rotated, turn each screw until snug, but not tight.

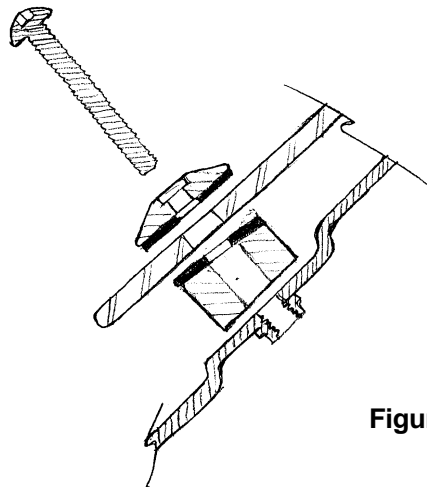

Figure 1